

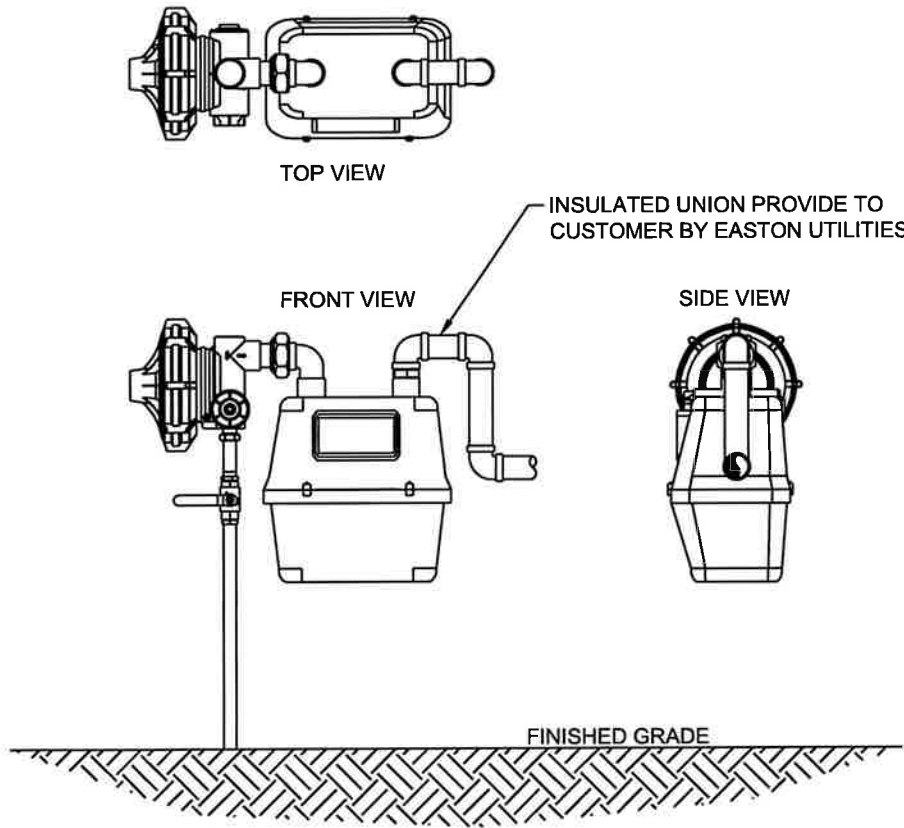

O:\standets\REVISED 2024\REVISED-RENUMBERED 2024\GS-101.1.dwg, 1/30/2024 10:30:04 AM, 1:1



NOTES:

1. BEFORE GAS SERVICE IS INSTALLED, SERVICE APPLICATION MUST BE MADE AT EASTON UTILITIES CUSTOMER SERVICE CENTER.
2. ALL GAS METER SETS SHALL BE INSTALLED TO NFPA54 ANSI Z 223.1 NATIONAL FUEL GAS CODE AND EASTON UTILITIES GAS DEPARTMENT STANDARD.
3. GAS SERVICE RISER SHALL BE SLEEVED IN PVC CONDUIT IF IT PASSES THROUGH CONCRETE, BRICK OR PAVEMENT.
4. EASTON UTILITIES GAS DEPARTMENT SHALL BE CONTACTED REGARDING METER LOCATION AND PRESSURE TESTING REQUIREMENTS.
5. GAS METER SHALL BE LOCATED IN A VENTILATED SPACE CLEAR OF LANDSCAPING AND READILY ACCESSIBLE FOR EXAMINATION, READING, REPLACEMENT OR NECESSARY MAINTENANCE.
6. IF GAS METER IS EQUIPPED WITH A REGULATOR, IT SHALL BE LOCATED AT LEAST 3 FEET FROM AIR VENTS, INLETS AND ANY SOURCE THAT CAN DAMAGE METER.
7. PER COMAR 20.55.09.07 - GAS SERVICE MAY NOT BE PROVIDED TO NEW OR RENEWED SERVICE LINES IF THERE IS ANY UNDERGROUND PIPELINE AFTER THE METER, UNLESS THE PIPELINE CARRIES GAS ONLY TO GAS UTILIZATION EQUIPMENT LOCATED OUTDOORS.

 Life. Made better.™	APPROVAL	REVISED	EASTON UTILITIES STANDARD DETAILS GAS METER INSTALLATION	
	 EU ENGINEERING DEPARTMENT			
	1/31/2024 DATE			
	ISSUED: JANUARY 2024			STANDARD NO.: GS-101.1