

O:\standets\REVISED 2024\REVISED-RENUMBERED 2024\SS-101.5.dwg, 1/31/2024 8:39:50 AM, 1:1

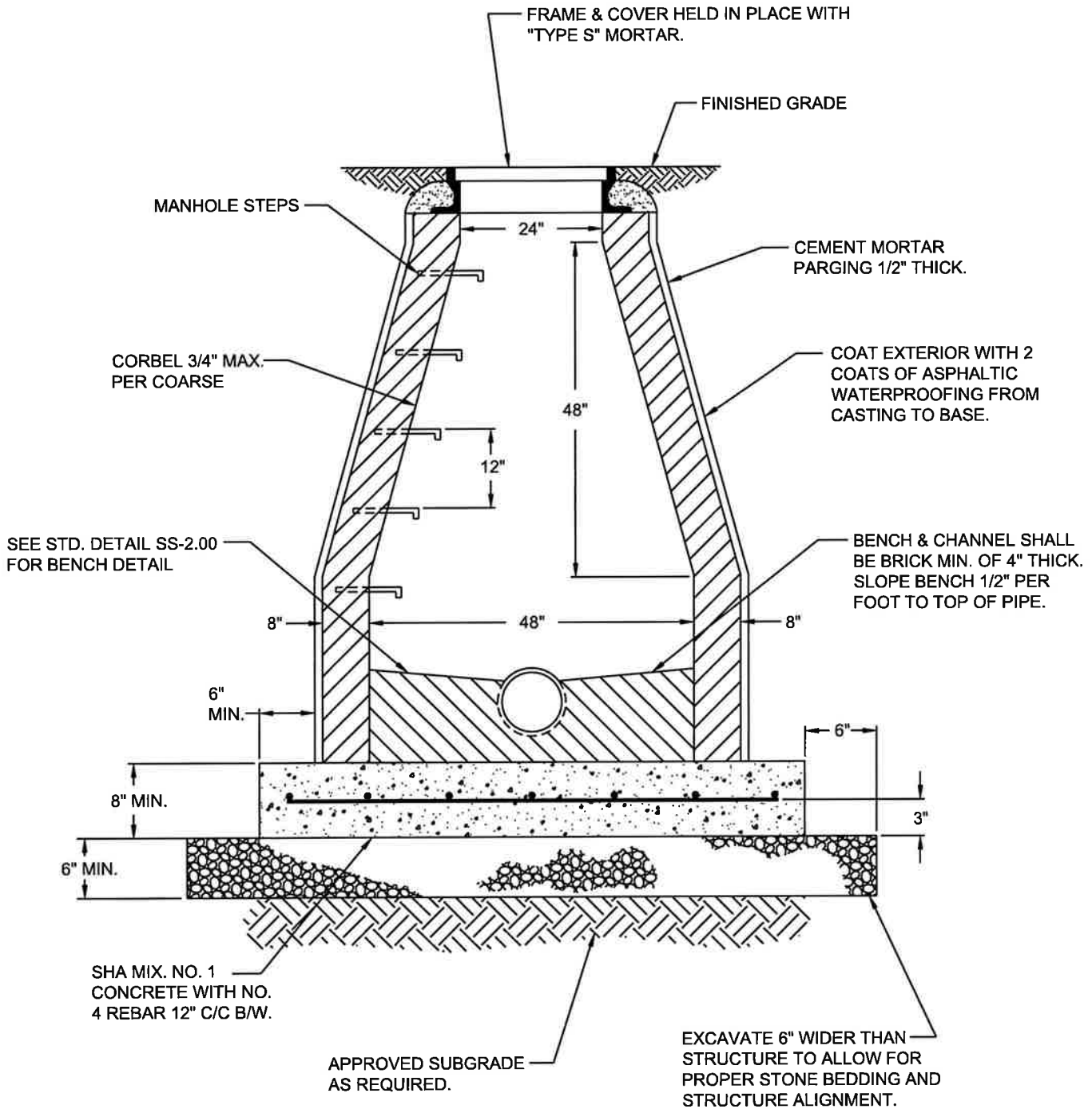
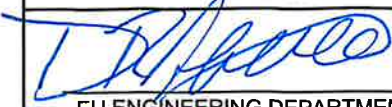

NOTE:
1. MORTAR SHALL BE "TYPE S".

 Life. Made better.™	APPROVAL	REVISED	EASTON UTILITIES STANDARD DETAILS BRICK MANHOLE	
	 EU ENGINEERING DEPARTMENT			
	1/31/2024 DATE			
	ISSUED: JANUARY 2024			
				STANDARD NO.: SS-101.5