

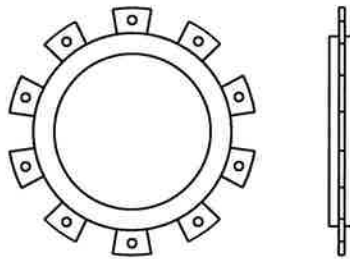

O:\standets\REVISED 2024\REVISED-RENUMBERED 2024\W-101.4.dwg, 1/30/2024 12:03:06 PM, 1:1

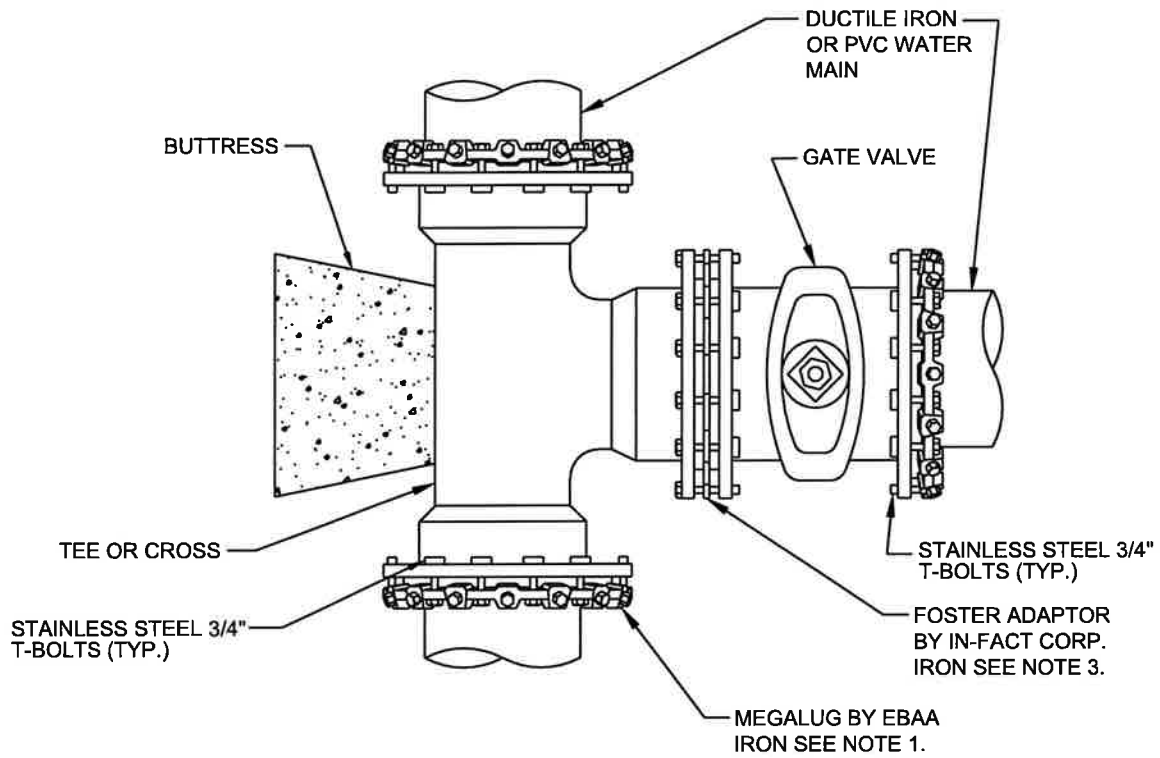

FOSTER ADAPTOR
SIZES VARIE

NOTES:

1. MEGALUG BY EBAA IRON: 1100 SERIES FOR DUCTILE IRON PIPE AND 2200 SERIES FOR PVC PIPE.
2. ALL FITTINGS SHALL BE MECHANICAL JOINT, WITH DUCTILE IRON RETAINER GLANDS AND MEGALUG OR EQUIVALENT RESTRAINT.
3. FOSTER ADAPTOR BY IN-FACT CORPORATION OR EQUIVALENT. ADAPTOR SHALL BE EPOXY COATED.
4. FOSTER ADAPTOR TO BE UTILIZED ONLY AS APPROVED BY EASTON UTILITIES ENGINEER.

 Life. Made better.™	APPROVAL	REVISED	EASTON UTILITIES STANDARD DETAILS MJ x MJ ADAPTOR	
	 EU ENGINEERING DEPARTMENT			
	1/31/2024 DATE			
	ISSUED: JANUARY 2024			STANDARD NO.: W-101.4