

OUTDOOR INSTALLATION

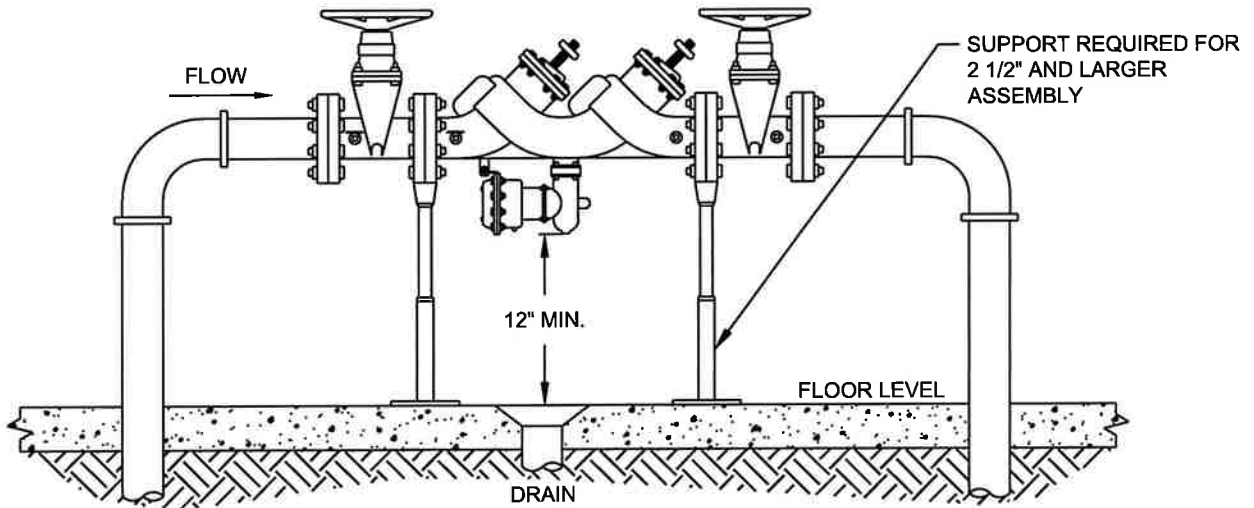

INDOOR INSTALLATION

NOTES:

1. REDUCED PRESSURE BACKFLOW PREVENTER TO BE MANUFACTURED BY FEBCO OR AN APPROVED EQUAL.
2. ASSEMBLY TO BE USED FOR PIPE 2 1/2" TO 10".
3. ASSEMBLY SHALL BE SUBMITTED TO EASTON UTILITIES FOR APPROVAL.
4. INSTALL WHERE ASSEMBLY IS ACCESSIBLE FOR PERIODIC TESTING AND SPILLAGE IS NOT OBJECTIONABLE.
5. OUTDOOR ASSEMBLIES WILL ONLY BE PERMITTED WHEN ACCOMPANIED BY AN ASSE 1060 APPROVED CLASS 1 ENCLOSURE.
6. BACKFLOW ASSEMBLIES SHALL NOT BE PERMITTED BELOW GRADE.
7. NO BYPASS IS PERMITTED.

O:\standets\REVISED 2024\REVISED-RENUMBERED 2024\W-102.5.dwg, 1/30/2024 1:01:44 PM, 1:1



Life. Made better.™

	APPROVAL	REVISED	
	 EU ENGINEERING DEPARTMENT 1/31/2024 DATE		<b>EASTON UTILITIES STANDARD DETAILS</b>  <b>REDUCED PRESSURE BACKFLOW PREVENTER GREATER THAN 2" DIA.</b>
	<b>ISSUED: JANUARY 2024</b>		<b>STANDARD NO.: W-102.5</b>